

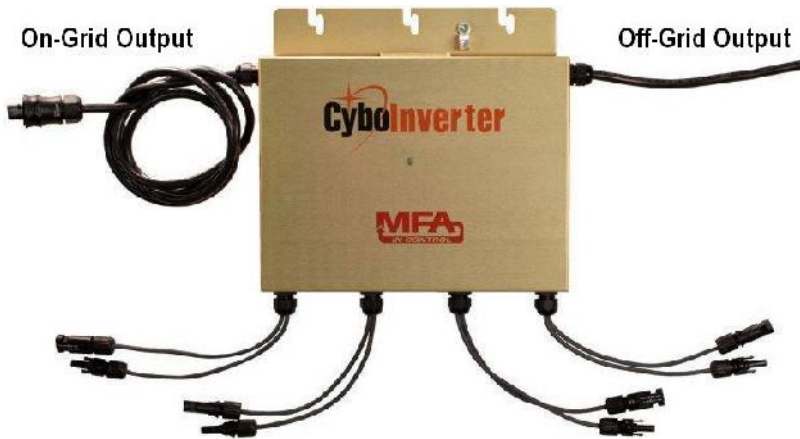

The World's First On/Off-Grid Solar & Hybrid Power Mini-Inverter



- On-Grid or Off-Grid Mode
- Specially Designed to Provide Backup Power When the Grid is Down
- Four DC Input Channels for Solar, Battery, or Wind Input
- Over Discharge Protection for 48V Lead-Acid Batteries
- Pure Sinewave AC Output
- MPPT for Each Solar Panel
- Outdoor or Indoor Mounting

Each CyboInverter (CIM-1200A/Y) can connect to 4 solar, battery, or wind DC sources and produce 1150W, 240V, 60Hz AC to the grid when grid is on, or 240V AC to an off-grid circuit to run AC loads.

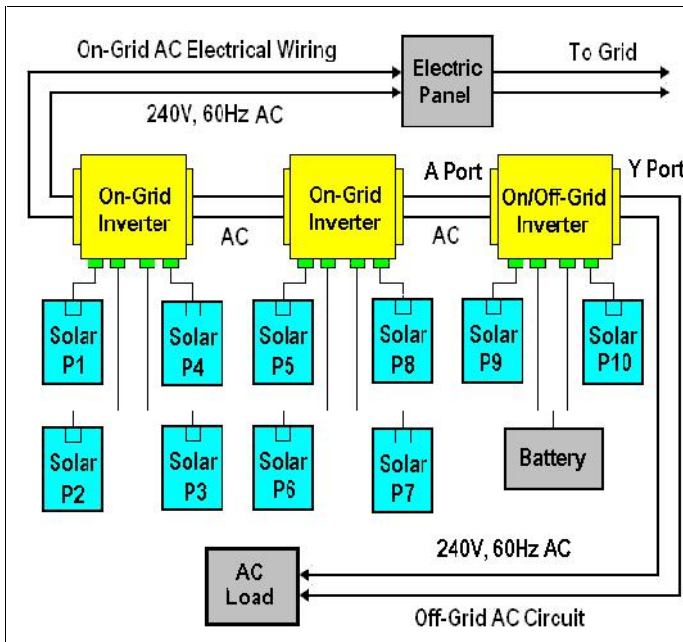

When the grid is on, the inverter works like a regular on-grid inverter that meets UL1741 and IEEE1547 standards including: over and under voltage shutdown; over and under frequency shutdown; and anti-islanding.

When the grid is down, the inverter will shutdown immediately and then send a test signal from its off-grid output port to check the status of the connected off-grid AC circuit. If there is no AC present and an AC load is detected, it will generate AC to power the load.

In the off-grid mode, when the inverter detects the grid is back on, it will stop powering the load. After a 5-minute UL mandatory wait, the inverter will send AC power to the grid again.

The drawing shows 2 on-grid and 1 on/off-grid CyboInverters daisy-chained as a group.

Product: 4 Channel 1.2KW On/Off-Grid CyboInverter for Solar, Wind & Battery
Part No: CIM-1200A/Y Maximum CyboInverters per 20A Branch Circuit: 3-4

Technical Data of CIM-1200A/Y (Rev 5.1 - June 2017)

DC Input (per Channel)	60/72 Cell Panel	Battery	DC Wind Gen
Recommended Input Power	250W – 330W	48V, 100AH	200W – 300W
Operating Input DC Voltage Range	15V – 58V	47V – 58V	20V – 45V
Peak Power Performance Range	30V – 58V	48V – 58V	20V – 40V
Maximum Input DC Voltage / Current	58V / 9A	58V / 9A	48V / 9A
Maximum Input Power	300W	300W	300W
Minimum Starting Voltage	20V	47V	20V
Compatible Solar Panels	Most 60-Cell and 72-Cell PV Solar Panels		
Compatible Batteries	48V Lead-Acid Deep-Cycle AGM or Lithium-Ion Pack		
AC Output	On-Grid, A Port	Off-Grid, Y Port	
Rated Output Power / Peak Output Power	960W / 1150W	960W / 1150W	
Nominal Output Current (RMS)	4A	4A	
Nominal Output Voltage / Range	240V (211V – 264V)	240V (216V – 264V)	
Nominal Frequency / Range	60Hz (59.3 – 60.5) Hz	60Hz (59.5 – 60.5) Hz	
Power Factor / Harmonic Distortion	>0.95 (THD < 4%, 2 nd Harmonic < 1%)		
Efficiency	Data		
Peak Efficiency / Solar MPPT Tracking	96% / 99%		
Mechanical Data	SI	U.S.	
Ambient Temperature Range	-40°C to +65°C	-40°F to +149°F	
Internal Operating Temperature Range	-40°C to +88°C	-40°F to +190°F	
Dimensions w/o mounting bracket (L x H x W)	32cm x 24cm x 5.8cm	12.5" x 9.5" x 2.3"	
Weight	6.5 kg	14.25 lbs	
Cooling / Enclosure	Natural Convection, No Fan / Potted		
DC Connectors / AC Connectors	MC-4 or Compatible / Wieland RST 3-Conductor		
Compliance and Features	Data		
Safety and EMC Compliance	UL1741 and IEEE1547 (E113426), CSA 107.1, FCC Part 15 Class A. NEC 690.12 Rapid Shutdown of PV Systems.		
DC Ground Fault Detector Interrupter (GFDI)	Built-In		
Standard Warranty	3 Years (Extended Warranty Available)		
Enclosure Environmental Rating / Safety	Outdoor, NEMA 6 (IP67) / Transformer Isolated Circuits		

Made in U.S.A.